

# LSM-E Series User's Manual

Miniature motorized linear stages with built-in motor encoders



## Disclaimer

---

Zaber's devices are not intended for use in any critical medical, aviation, or military applications or situations where a product's use or failure could cause personal injury, death, or damage to property. Zaber disclaims any and all liability for injury or other damages resulting from the use of our products.

## Precautions

---

Zaber's autodetect peripheral axes are designed to be used effortlessly with Zaber's line of autodetect controllers. The LSM-E includes onboard memory that allows Zaber's controllers to autodetect the model and set reasonable parameters. See the [Protocol Manual](#) for more information on how to modify the settings. Damage to the axis may result if the settings are not correct. To use your Zaber peripheral with a third-party controller, review the motor, sensor, and encoder specifications and pin-outs carefully.

Zaber's motion control devices are precision instruments and must be handled with care. In particular, moving parts must be treated with care. Avoid axial loads in excess of the rated thrust load, axial and radial impact, dust and other contaminants and damage to the lead screw thread. These will reduce the performance of the device below stated specifications.

## Conventions used throughout this document

---

- Fixed width type indicates communication to and from a device. The ↵ symbol indicates a carriage return, which can be achieved by pressing enter when using a terminal program.
- An [ASCII command](#) followed by (T:xx) indicates a legacy T-Series [Binary Protocol](#) command that achieves the same result. For example, `move abs 10000 (T:20:10000)` shows that a move abs ASCII command can also be achieved with Binary command number 20. Not all ASCII commands have an equivalent Binary counterpart.

## Device Overview

---

## AutoDetect

Your LSM-E peripheral is equipped with AutoDetect, a feature that allows a Zaber controller to automatically configure its settings for the peripheral when it is connected.



**Important:** The controller should always be powered down before disconnecting or connecting your LSM-E peripheral.

To connect the peripheral to a controller:



1. Power off the controller.
2. Connect the LSM-E peripheral.
3. Power on the controller.
4. The controller will activate the peripheral shortly after it is powered on.

## Connectors

Recommended controller(s) for your LSM-E peripheral are provided in the product specifications. Zaber's controllers and peripherals are designed for ease of use when used together. Optimal settings for each peripheral are automatically detected by Zaber's controllers when the device is connected.

For reference, the pinout for the peripheral cable connectors is shown below:

### Pinout for D-sub 15 Connectors (peripherals)

T3A Peripheral (male)		
T4A Peripheral (male)		
Pin #	Function	
1	+5V for Limits & Encoder	
2	AutoDetect Data	
3	<i>reserved</i>	
4	Away Sensor	

5	Home Sensor
6	Ground
7	Motor B1
8	Motor A1
9	AutoDetect Clock
10	Encoder A
11	Encoder B
12	Encoder Index
13	Ground
14	Motor B2
15	Motor A2

*Not all pins are used for all models*

## Alternate Controllers

The LSM-E can be controlled by any 2-phase stepper motor controller with limit sensor and appropriate encoder input. **We do not recommend using your own controller unless you are familiar with how to control a stepper motor with hall sensor limit switches.** Damage to the stage due to incorrect wiring is not covered by warranty.

### Motors & Encoders

For motor and encoder information see the [LSM-E product page](#)

### Limit Sensors

Hall effect sensors are used in the LSM-E as home sensors. The Hall sensors used are part number A1120LLHLT-T made by Allegro. [Click here for data sheet](#). Your controller should be configured so the stage stops immediately (quick deceleration) when the sensors are triggered.

- PCB wire colour code:
  - 3.6-24 Vdc input - red
  - Home signal - yellow
  - Away signal - white
  - Ground - black

The Hall sensor has an open-collector output. The default output is high impedance when the Hall sensor is not active. When the sensor detects a magnet, the Hall sensor pulls the output low to ground.

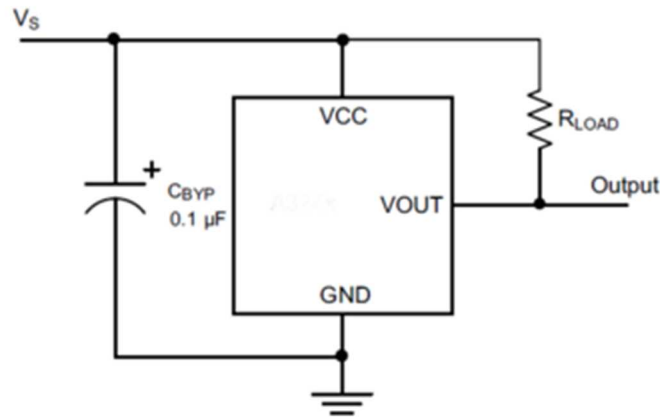

If you are not using a Zaber controller, ensure that your controller has a pull-up resistor on the output line of each Hall sensor as shown in the diagram. The bypass capacitor is optional, but may help to eliminate false triggering in noisy environments. The typical value for the pull-up resistor ( $R_{LOAD}$ ) is 10 k $\Omega$  and for the bypass capacitor is 0.1  $\mu$ F to 1  $\mu$ F. The larger the capacitance, the better the noise filtering but the slower the response time.

## Installation

---

### Mounting

There are several options available for mounting Zaber stages. Use the mounting holes in the bottom to mount to a surface or to another stage. You might have to move the carriage to access the bottom mounting holes. Some stages have mounting holes in the end plates for mounting vertically. Mounting screws are included with most stages.

**Caution:** Some stages have threaded through-holes in the top mounting plate of the carriage. Be sure not to install mounting screws too deep, causing them to interfere with inside parts of the stage.

LSM-E stages can be mounted to a standard metric or imperial breadboard with our [AP101 adaptor plates](#).

## Warranty and Repair

---

For Zaber's policies on warranty and repair, please refer to the [Ordering Policies](#).

### Standard products

Standard products are any part numbers that do not contain the suffix ENG followed by a 4 digit number. Most, but not all, standard products are listed for sale on our website. All standard Zaber products are backed by a one-month satisfaction guarantee. If you are not satisfied with your purchase, we will refund your payment minus any shipping charges. Goods must be in brand new saleable condition with no marks. Zaber products are guaranteed for one year. During this period Zaber will repair any products with faults due to manufacturing defects, free of charge.

## Custom products

Custom products are any part numbers containing the suffix ENG followed by a 4 digit number. Each of these products has been designed for a custom application for a particular customer. Custom products are guaranteed for one year, unless explicitly stated otherwise. During this period Zaber will repair any products with faults due to manufacturing defects, free of charge.

## How to return products

Customers with devices in need of return or repair should contact Zaber to obtain an RMA form which must be filled out and sent back to us to receive an RMA number. The RMA form contains instructions for packing and returning the device. The specified RMA number must be included on the shipment to ensure timely processing.

## Email Updates

---

If you would like to receive our periodic email newsletter including product updates and promotions, please sign up online at [www.zaber.com \(news section\)](http://www.zaber.com/news-section). Newsletters typically include a promotional offer worth at least \$100.

## Contact Information

---

Contact Zaber Technologies Inc by any of the following methods:

<b>Phone</b>	1-604-569-3780 (direct) 1-888-276-8033 (toll free in North America)
<b>Fax</b>	1-604-648-8033
<b>Mail</b>	#2 – 605 West Kent Ave. N., Vancouver, British Columbia, Canada, V6P 6T7
<b>Web</b>	<a href="http://www.zaber.com">www.zaber.com</a>
<b>Email</b>	Please visit our website for up to date email contact information.

The original instructions for this product are available at <https://www.zaber.com/manuals/LSM-E>.

## Appendix A: Default Settings

---

Please see [the Zaber Support Page](#) for default settings for this device.

## Product Drawing

---

# ZABER

LSM-E Miniature Motorized Linear Stage  
dimensions in mm

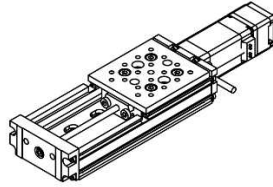

Model Number*	Travel	A	B
LSM025-E	25.4	144.8	75.8
LSM050-E	50.8	170.2	101.2
LSM100-E	101.6	221.0	152.0
LSM150-E	152.4	271.8	202.8
LSM200-E	203.2	322.6	253.6

\*See product page for complete list of available models at [www.zaber.com](http://www.zaber.com)

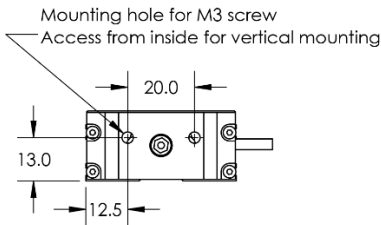
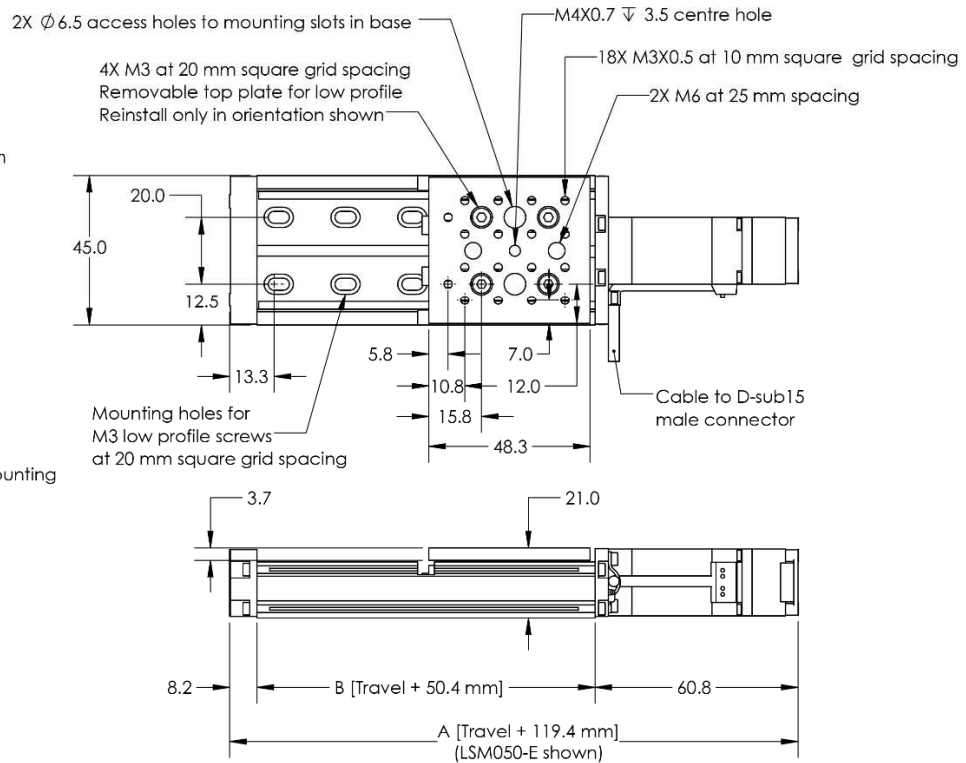

DWG 1178 9/01

## Specifications

Specification	Value	Alternate Unit
<a href="#">Built-in Controller</a>	No	
<a href="#">Recommended Controller</a>	<a href="#">X-MCC</a> (48 V) Recommended	
<a href="#">AutoDetect</a>	Yes	
<a href="#">Encoder Resolution</a>	200 CPR	800 states/rev
<a href="#">Encoder Type</a>	Rotary quadrature encoder	
<a href="#">Maximum Continuous Thrust</a>	25 N	5.6 lb
<a href="#">Maximum Centered Load</a>	100 N	22.4 lb
<a href="#">Maximum Cantilever Load</a>	300 N · cm	424.8 oz · in
<a href="#">Guide Type</a>	Needle roller bearing	
<a href="#">Stiffness in Pitch</a>	55 N · m/°	317 $\mu$ rad/N · m
<a href="#">Stiffness in Roll</a>	52.5 N · m/°	332 $\mu$ rad/N · m
<a href="#">Stiffness in Yaw</a>	85 N · m/°	205 $\mu$ rad/N · m
<a href="#">Motor Steps Per Rev</a>	200	
<a href="#">Motor Type</a>	Stepper (2 phase)	
<a href="#">Motor Rated Current</a>	600 mA/phase	
<a href="#">Motor Winding Resistance</a>	6.5 ohms/phase	
<a href="#">Inductance</a>	3.5 mH/phase	
<a href="#">Motor Rotor Inertia</a>	2.9 g · cm <sup>2</sup>	

Specification	Value	Alternate Unit
<a href="#">Motor Connection</a>	D-sub 15	
<a href="#">Default Resolution</a>	1/64 of a step	
<a href="#">Motor Frame Size</a>	NEMA 08	
<a href="#">Mechanical Drive System</a>	Precision lead screw	
<a href="#">Limit or Home Sensing</a>	Magnetic hall sensor	
<a href="#">Axes of Motion</a>	1	
<a href="#">Mounting Interface</a>	M3 and M6 threaded holes and M4 threaded centre hole	
<a href="#">Operating Temperature Range</a>	0 to 50 ° C	
<a href="#">Vacuum Compatible</a>	No	
<a href="#">RoHS Compliant</a>	Yes	
<a href="#">Stage Parallelism</a>	< 25 µm	< 0.000984"
<a href="#">CE Compliant</a>	Yes	

### Comparison

Part Number	<a href="#">Microstep Size</a> (Default Resolution)	<a href="#">Travel Range</a>	<a href="#">Accuracy</a> (unidirectional)	<a href="#">Repeatability</a>
LSM025A-E03T4A	0.047625 µm	25.4 mm (1.000")	15 µm (0.000591")	< 3 µm (< 0.000118")
LSM025B-E03T4A	0.1905 µm	25.4 mm (1.000")	15 µm (0.000591")	< 6 µm (< 0.000236")
LSM050A-E03T4A	0.047625 µm	50.8 mm (2.000")	20 µm (0.000787")	< 3 µm (< 0.000118")
LSM050B-E03T4A	0.1905 µm	50.8 mm (2.000")	25 µm (0.000984")	< 6 µm (< 0.000236")
LSM100A-E03T4A	0.047625 µm	101.6 mm (4.000")	35 µm (0.001378")	< 3 µm (< 0.000118")
LSM100B-E03T4A	0.1905 µm	101.6 mm (4.000")	45 µm (0.001772")	< 6 µm (< 0.000236")
LSM150A-E03T4A	0.047625 µm	152.4 mm (6.000")	50 µm (0.001968")	< 3 µm (< 0.000118")
LSM150B-E03T4A	0.1905 µm	152.4 mm (6.000")	65 µm (0.002559")	< 6 µm (< 0.000236")
LSM200A-E03T4A	0.047625 µm	203.2 mm (8.000")	60 µm (0.002362")	< 3 µm (< 0.000118")
LSM200B-E03T4A	0.1905 µm	203.2 mm (8.000")	85 µm (0.003346")	< 6 µm (< 0.000236")

Part Number	<a href="#">Backlash</a>	<a href="#">Maximum Speed</a>	<a href="#">Minimum Speed</a>	<a href="#">Speed Resolution</a>
LSM025A-E03T4A	< 12 µm (< 0.000472")	26 mm/s (1.024"/s)	0.000029 mm/s (0.000001"/s)	0.000029 mm/s (0.000001"/s)
LSM025B-E03T4A	< 16 µm (< 0.000630")	104 mm/s (4.094"/s)	0.000116 mm/s (0.000005"/s)	0.000116 mm/s (0.000005"/s)
LSM050A-E03T4A	< 12 µm (< 0.000472")	26 mm/s (1.024"/s)	0.000029 mm/s (0.000001"/s)	0.000029 mm/s (0.000001"/s)
LSM050B-E03T4A	< 16 µm (< 0.000630")	104 mm/s (4.094"/s)	0.000116 mm/s (0.000005"/s)	0.000116 mm/s (0.000005"/s)

Part Number	<u>Backlash</u>	<u>Maximum Speed</u>	<u>Minimum Speed</u>	<u>Speed Resolution</u>
LSM100A-E03T4A	< 12 μm (< 0.000472")	26 mm/s (1.024"/s)	0.000029 mm/s (0.000001"/s)	0.000029 mm/s (0.000001"/s)
LSM100B-E03T4A	< 16 μm (< 0.000630")	104 mm/s (4.094"/s)	0.000116 mm/s (0.000005"/s)	0.000116 mm/s (0.000005"/s)
LSM150A-E03T4A	< 12 μm (< 0.000472")	26 mm/s (1.024"/s)	0.000029 mm/s (0.000001"/s)	0.000029 mm/s (0.000001"/s)
LSM150B-E03T4A	< 16 μm (< 0.000630")	104 mm/s (4.094"/s)	0.000116 mm/s (0.000005"/s)	0.000116 mm/s (0.000005"/s)
LSM200A-E03T4A	< 12 μm (< 0.000472")	26 mm/s (1.024"/s)	0.000029 mm/s (0.000001"/s)	0.000029 mm/s (0.000001"/s)
LSM200B-E03T4A	< 16 μm (< 0.000630")	104 mm/s (4.094"/s)	0.000116 mm/s (0.000005"/s)	0.000116 mm/s (0.000005"/s)

Part Number	<u>Peak Thrust</u>	<u>Vertical Runout</u>	<u>Horizontal Runout</u>	<u>Pitch</u>
LSM025A-E03T4A	55 N (12.3 lb)	< 8 μm (< 0.000315")	< 12 μm (< 0.000472")	0.02° (0.349 mrad)
LSM025B-E03T4A	25 N (5.6 lb)	< 8 μm (< 0.000315")	< 12 μm (< 0.000472")	0.02° (0.349 mrad)
LSM050A-E03T4A	55 N (12.3 lb)	< 11 μm (< 0.000433")	< 14 μm (< 0.000551")	0.03° (0.523 mrad)
LSM050B-E03T4A	25 N (5.6 lb)	< 11 μm (< 0.000433")	< 14 μm (< 0.000551")	0.03° (0.523 mrad)
LSM100A-E03T4A	55 N (12.3 lb)	< 18 μm (< 0.000709")	< 18 μm (< 0.000709")	0.04° (0.698 mrad)
LSM100B-E03T4A	25 N (5.6 lb)	< 18 μm (< 0.000709")	< 18 μm (< 0.000709")	0.04° (0.698 mrad)
LSM150A-E03T4A	55 N (12.3 lb)	< 25 μm (< 0.000984")	< 23 μm (< 0.000906")	0.04° (0.698 mrad)
LSM150B-E03T4A	25 N (5.6 lb)	< 25 μm (< 0.000984")	< 23 μm (< 0.000906")	0.04° (0.698 mrad)
LSM200A-E03T4A	55 N (12.3 lb)	< 32 μm (< 0.001260")	< 27 μm (< 0.001063")	0.04° (0.698 mrad)
LSM200B-E03T4A	25 N (5.6 lb)	< 32 μm (< 0.001260")	< 27 μm (< 0.001063")	0.04° (0.698 mrad)

Part Number	<u>Roll</u>	<u>Yaw</u>	<u>Linear Motion Per Motor Rev</u>	<u>Weight</u>
LSM025A-E03T4A	0.02° (0.349 mrad)	0.03° (0.523 mrad)	0.6096 mm (0.024")	0.26 kg (0.573 lb)
LSM025B-E03T4A	0.02° (0.349 mrad)	0.03° (0.523 mrad)	2.4384 mm (0.096")	0.26 kg (0.573 lb)
LSM050A-E03T4A	0.03° (0.523 mrad)	0.03° (0.523 mrad)	0.6096 mm (0.024")	0.28 kg (0.617 lb)
LSM050B-E03T4A	0.03° (0.523 mrad)	0.03° (0.523 mrad)	2.4384 mm (0.096")	0.28 kg (0.617 lb)
LSM100A-E03T4A	0.04° (0.698 mrad)	0.04° (0.698 mrad)	0.6096 mm (0.024")	0.32 kg (0.705 lb)
LSM100B-E03T4A	0.04° (0.698 mrad)	0.04° (0.698 mrad)	2.4384 mm (0.096")	0.32 kg (0.705 lb)
LSM150A-E03T4A	0.05° (0.873 mrad)	0.05° (0.873 mrad)	0.6096 mm (0.024")	0.37 kg (0.816 lb)
LSM150B-E03T4A	0.05° (0.873 mrad)	0.05° (0.873 mrad)	2.4384 mm (0.096")	0.37 kg (0.816 lb)
LSM200A-E03T4A	0.05° (0.873 mrad)	0.05° (0.873 mrad)	0.6096 mm (0.024")	0.42 kg (0.926 lb)
LSM200B-E03T4A	0.05° (0.873 mrad)	0.05° (0.873 mrad)	2.4384 mm (0.096")	0.42 kg (0.926 lb)

## Charts and Notes



## Typical Accuracy

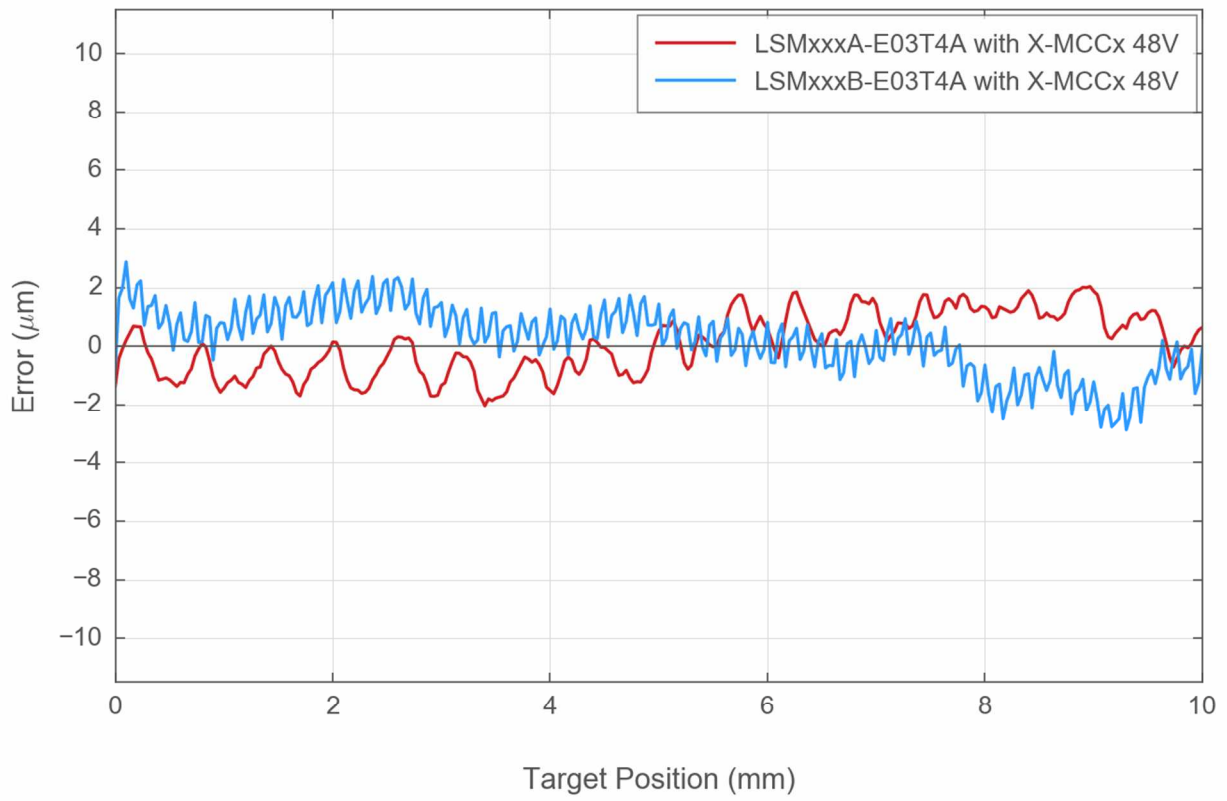

## Typical Microstepping Accuracy

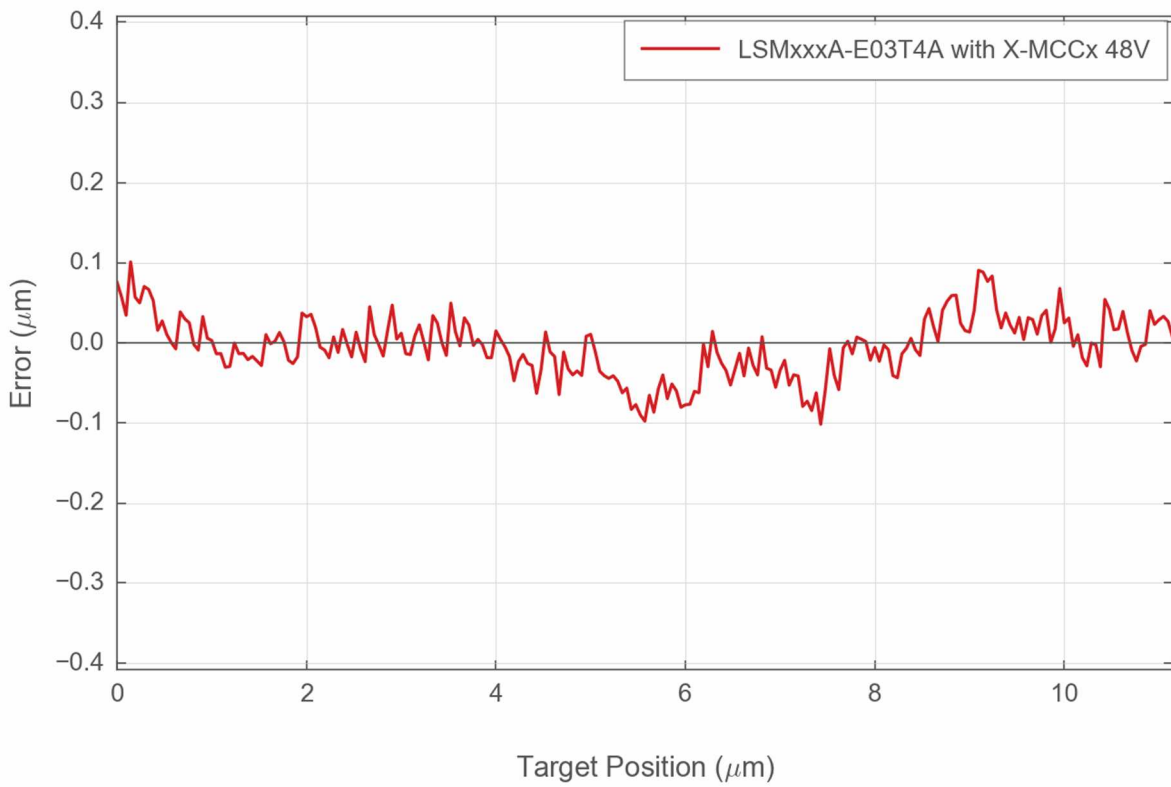

## Typical Microstepping Accuracy

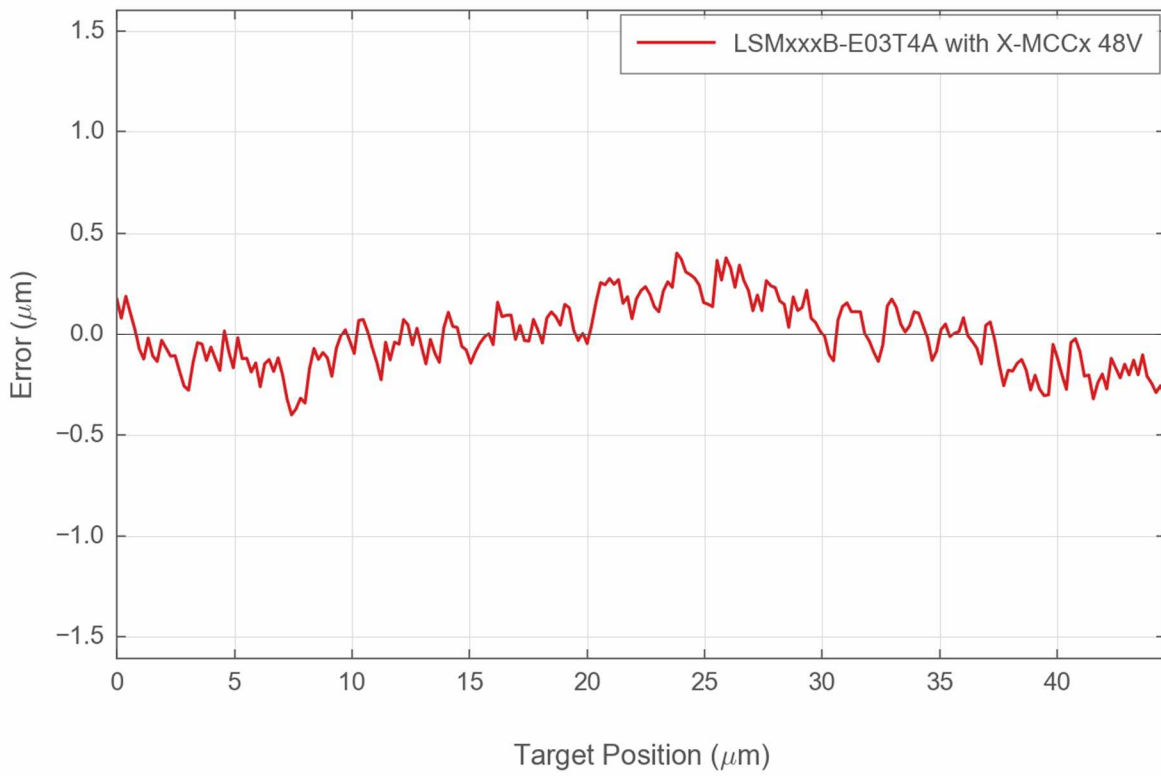

## Thrust Speed Performance

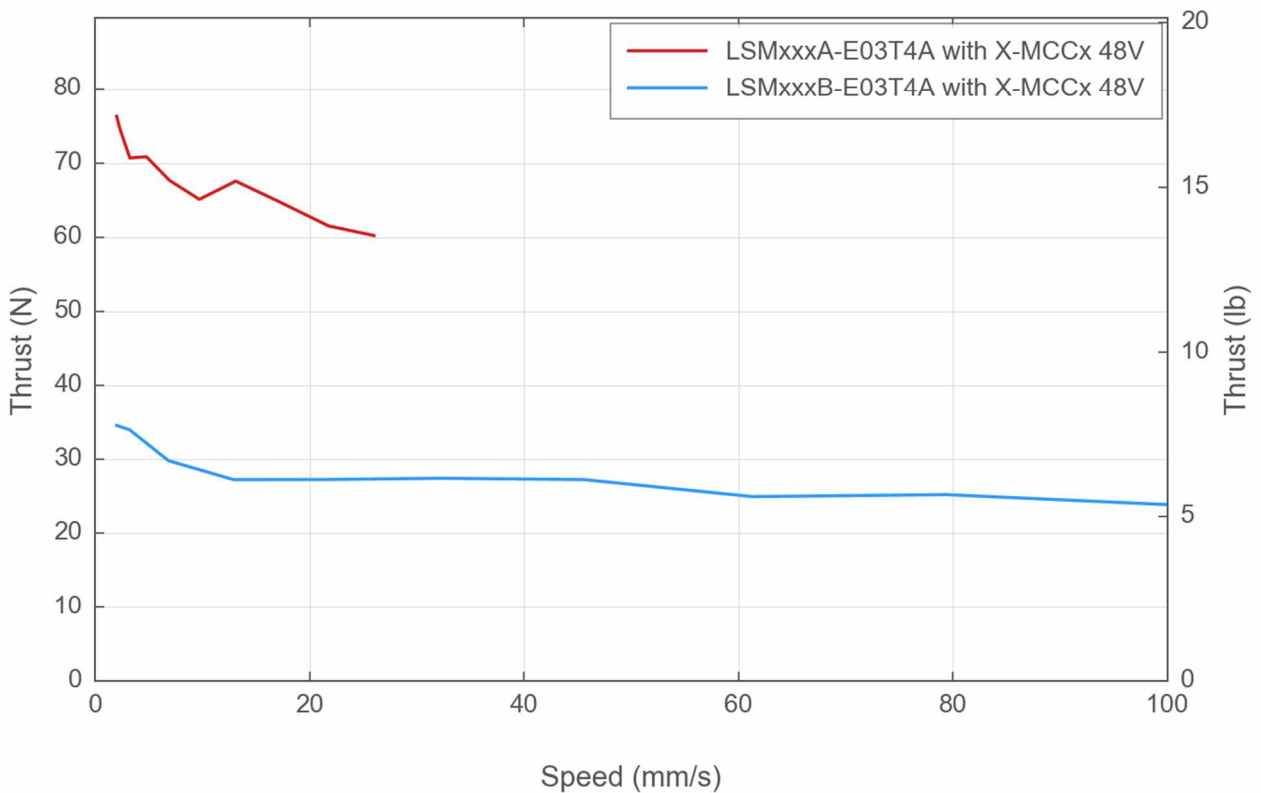

### Thrust Speed Performance

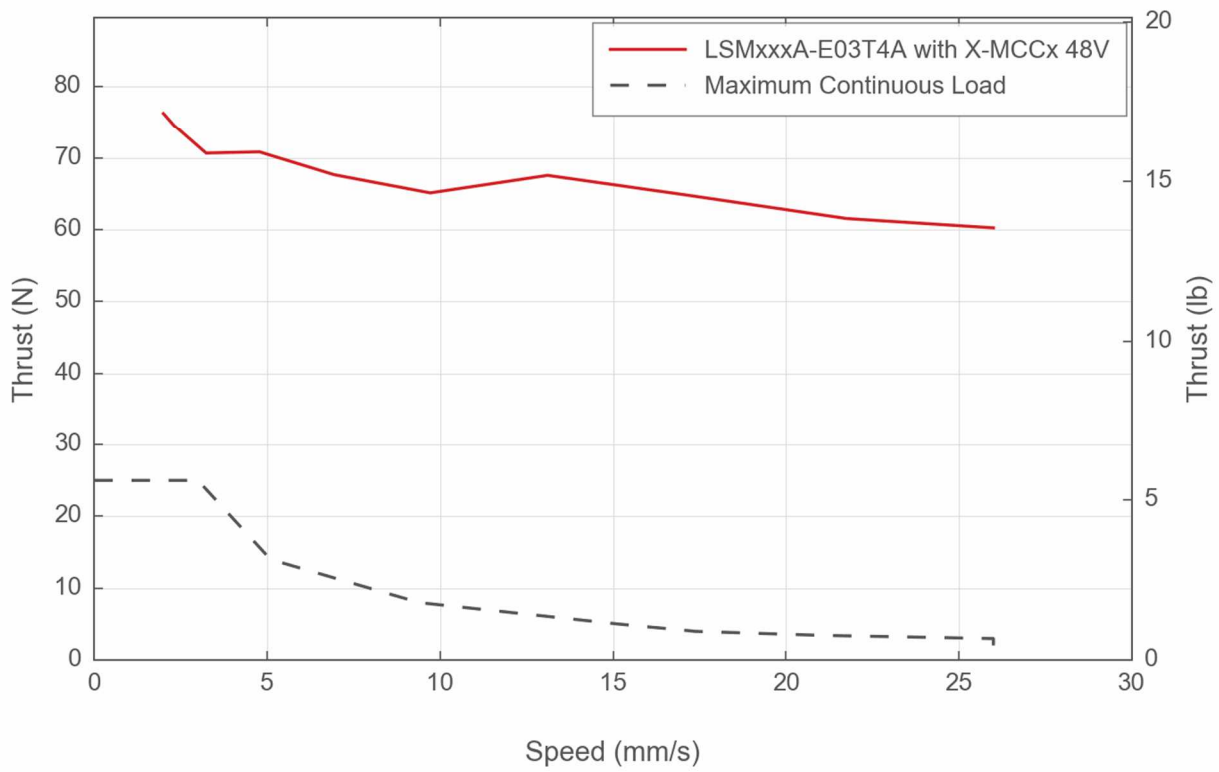

### Thrust Speed Performance

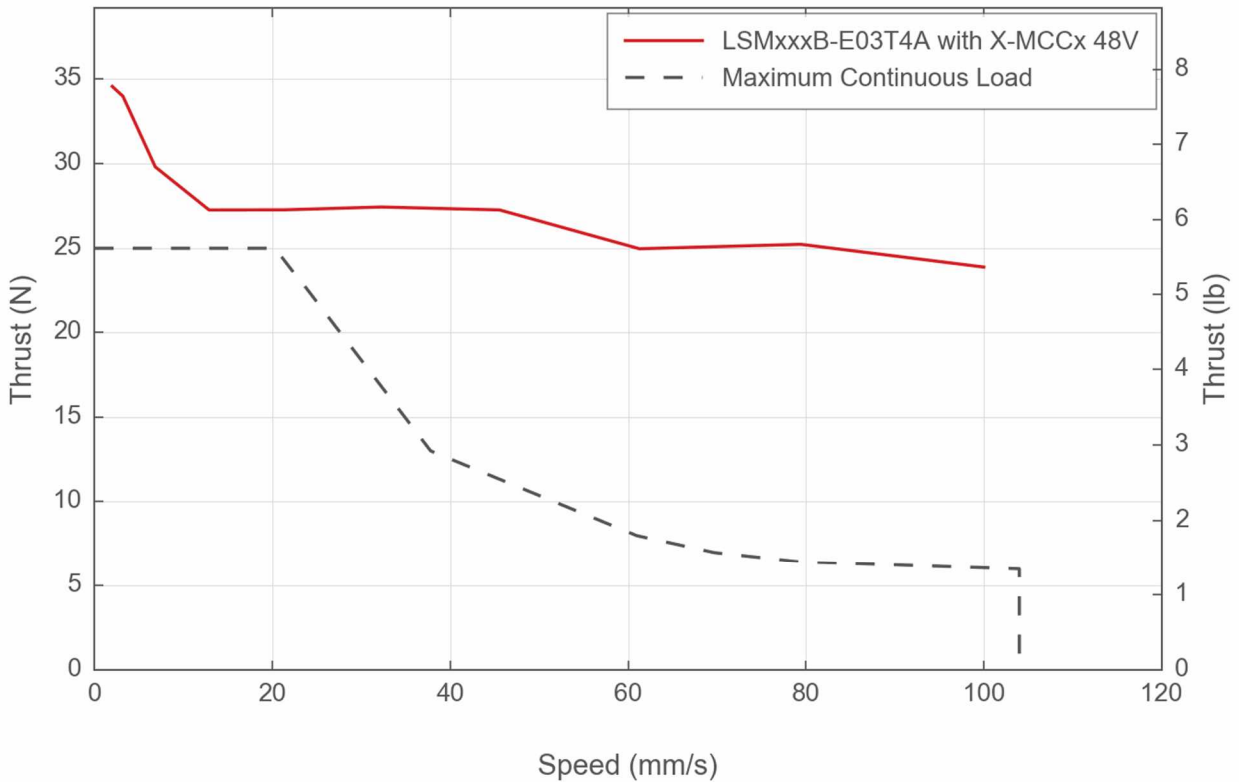

## LSM Linear Bearing Lifetime

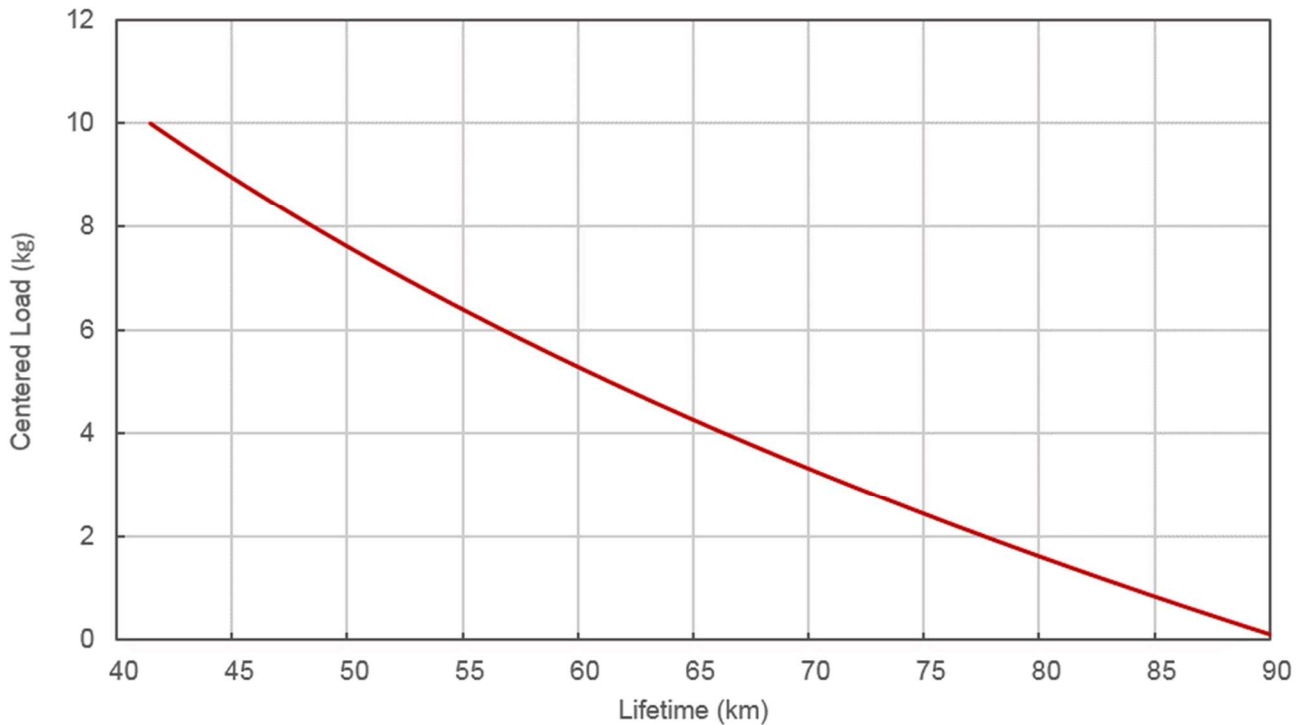

*This product uses the FreeRTOS kernel. FreeRTOS is © 2021 Amazon.com, Inc. or its affiliates and is governed by the following license:*

All rights reserved.

Permission is hereby granted, free of charge, to any person obtaining a copy of this software and associated documentation files (the "Software"), to deal in the Software without restriction, including without limitation the rights to use, copy, modify, merge, publish, distribute, sublicense, and/or sell copies of the Software, and to permit persons to whom the Software is furnished to do so, subject to the following conditions:

The above copyright notice and this permission notice shall be included in all copies or substantial portions of the Software.

THE SOFTWARE IS PROVIDED "AS IS", WITHOUT WARRANTY OF ANY KIND, EXPRESS OR IMPLIED, INCLUDING BUT NOT LIMITED TO THE WARRANTIES OF MERCHANTABILITY, FITNESS FOR A PARTICULAR PURPOSE AND NONINFRINGEMENT.

IN NO EVENT SHALL THE AUTHORS OR COPYRIGHT HOLDERS BE LIABLE FOR ANY CLAIM, DAMAGES OR OTHER LIABILITY, WHETHER IN AN ACTION OF CONTRACT, TORT OR OTHERWISE, ARISING FROM, OUT OF OR IN CONNECTION WITH THE SOFTWARE OR THE USE OR OTHER DEALINGS IN THE SOFTWARE.

*This product uses the LZ4 compression library. LZ4 is © 2011–2016 Yann Collet and is governed by the following license:*

All rights reserved.

Redistribution and use in source and binary forms, with or without modification, are permitted provided that the following conditions are met:

- Redistributions of source code must retain the above copyright notice, this list of conditions and the following disclaimer.
- Redistributions in binary form must reproduce the above copyright notice, this list of conditions and the following disclaimer in the documentation and/or other materials provided with the distribution.

THIS SOFTWARE IS PROVIDED BY THE COPYRIGHT HOLDERS AND CONTRIBUTORS "AS IS" AND ANY EXPRESS OR IMPLIED WARRANTIES, INCLUDING, BUT NOT LIMITED TO, THE IMPLIED WARRANTIES OF MERCHANTABILITY AND FITNESS FOR A PARTICULAR PURPOSE ARE DISCLAIMED. IN NO EVENT SHALL THE COPYRIGHT HOLDER OR CONTRIBUTORS BE LIABLE FOR ANY DIRECT, INDIRECT, INCIDENTAL, SPECIAL, EXEMPLARY, OR CONSEQUENTIAL DAMAGES (INCLUDING, BUT NOT LIMITED TO, PROCUREMENT OF SUBSTITUTE GOODS OR SERVICES; LOSS OF USE, DATA, OR PROFITS; OR BUSINESS INTERRUPTION) HOWEVER CAUSED AND ON ANY THEORY OF LIABILITY, WHETHER IN CONTRACT, STRICT LIABILITY, OR TORT (INCLUDING NEGLIGENCE OR OTHERWISE) ARISING IN ANY WAY OUT OF THE USE OF THIS SOFTWARE, EVEN IF ADVISED OF THE POSSIBILITY OF SUCH DAMAGE.