

LHM Series User's Manual

Economy motorized linear stage



Disclaimer

Zaber's devices are not intended for use in any critical medical, aviation, or military applications or situations where a product's use or failure could cause personal injury, death, or damage to property. Zaber disclaims any and all liability for injury or other damages resulting from the use of our products.

Precautions

Zaber's autodetect peripheral axes are designed to be used effortlessly with Zaber's line of autodetect controllers. The LHM includes onboard memory that allows Zaber's controllers to autodetect the model and set reasonable parameters. See the [Protocol Manual](#) for more information on how to modify the settings. Damage to the axis may result if the settings are not correct. To use your Zaber peripheral with a third-party controller, review the motor, sensor, and encoder specifications and pin-outs carefully.

Zaber's motion control devices are precision instruments and must be handled with care. In particular, moving parts must be treated with care. Avoid axial loads in excess of the rated thrust load, axial and radial impact, dust and other contaminants and damage to the lead screw thread. These will reduce the performance of the device below stated specifications.

Conventions used throughout this document

- Fixed width type indicates communication to and from a device. The ↵ symbol indicates a carriage return, which can be achieved by pressing enter when using a terminal program.
- An [ASCII command](#) followed by (T:xx) indicates a legacy T-Series [Binary Protocol](#) command that achieves the same result. For example, `move abs 10000 (T:20:10000)` shows that a move abs ASCII command can also be achieved with Binary command number 20. Not all ASCII commands have an equivalent Binary counterpart.

Device Overview

AutoDetect

Your LHM peripheral is equipped with AutoDetect, a feature that allows a Zaber controller to automatically configure its settings for the peripheral when it is connected.



Important: The controller should always be powered down before disconnecting or connecting your LHM peripheral.

To connect the peripheral to a controller:



1. Power off the controller.
2. Connect the LHM peripheral.
3. Power on the controller.
4. The controller will activate the peripheral shortly after it is powered on.

Connectors

Recommended controller(s) for your LHM peripheral are provided in the product specifications. Zaber's controllers and peripherals are designed for ease of use when used together. Optimal settings for each peripheral are automatically detected by Zaber's controllers when the device is connected.

For reference, the pinout for the peripheral cable connectors is shown below:

Pinout for D-sub 15 Connectors (peripherals)

T3A Peripheral (male)	
T4A Peripheral (male)	
Pin #	Function
1	+5V for Limits & Encoder
2	AutoDetect Data
3	<i>reserved</i>
4	Away Sensor
5	Home Sensor
6	Ground
7	Motor B1
8	Motor A1
9	AutoDetect Clock
10	Encoder A
11	Encoder B
12	Encoder Index
13	Ground
14	Motor B2
15	Motor A2

Not all pins are used for all models

Alternate Controllers

The LHM can be controlled by any 2-phase stepper motor controller with limit sensor input. **We do not recommend using your own controller unless you are familiar with how to control a stepper motor with hall sensor limit switches.** Damage to the stage due to incorrect wiring is not covered by warranty.

Motors

For motor information see the [LHM product page](#)

Limit Sensors

Hall effect sensors are used in the LHM as home sensors. The Hall sensors used are part number A1120LLHLT-T made by Allegro. [Click here for data sheet](#). Your controller should be configured so the stage stops immediately (quick deceleration) when the sensors are triggered.

- PCB wire colour code:
 - 3.6-24 Vdc input - red
 - Home signal - yellow
 - Away signal - white
 - Ground - black

The Hall sensor has an open-collector output. The default output is high impedance when the Hall sensor is not active. When the sensor detects a magnet, the Hall sensor pulls the output low to ground.

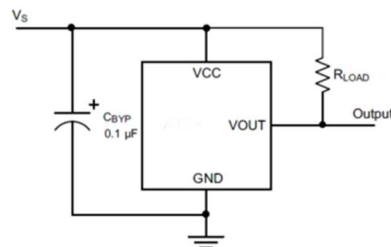

If you are not using a Zaber controller, ensure that your controller has a pull-up resistor on the output line of each Hall sensor as shown in the diagram. The bypass capacitor is optional, but may help to eliminate false triggering in noisy environments. The typical value for the pull-up resistor (R_{LOAD}) is $10 \text{ k}\Omega$ and for the bypass capacitor is $0.1 \mu F$ to $1 \mu F$. The larger the capacitance, the better the noise filtering but the slower the response time.

Installation

Physical Installation

Mounting

There are several options available for mounting Zaber stages. Use the mounting holes in the bottom to mount to a surface or to another stage. You might have to move the carriage to access the bottom mounting holes. Some stages have mounting holes in the end plates for mounting vertically. Mounting screws are included with most stages.

Caution: Some stages have threaded through-holes in the top mounting plate of the carriage. Be sure not to install mounting screws too deep, causing them to interfere with inside parts of the stage.

LHM series stages can be mounted to a standard metric or imperial breadboard with our [AP101 adaptor plates](#).

Grounding

To prevent damage to the device due to static buildup, the device should be properly grounded.

Failure to ground the unit may result in the unit shutting down unexpectedly or ceasing to communicate with the computer. This problem can be minimized by not touching the unit during operation. If the unit fails due to static discharge, unplugging it and plugging it back in or sending a Restore Settings command will usually fix the problem.

Most Zaber devices are grounded via the shield wire of the data cables. This should normally provide a path to ground via the computer. For units which are being used without a computer, a ground lead should be connected to the shield of one of the data cables.

Warranty and Repair

For Zaber's policies on warranty and repair, please refer to the [Ordering Policies](#).

Standard products

Standard products are any part numbers that do not contain the suffix ENG followed by a 4 digit number. Most, but not all, standard products are listed for sale on our website. All standard Zaber products are backed by a one-month satisfaction guarantee. If you are not satisfied with your purchase, we will refund your payment minus any shipping charges. Goods must be in brand new saleable condition with no marks. Zaber products are guaranteed for one year. During this period Zaber will repair any products with faults due to manufacturing defects, free of charge.

Custom products

Custom products are any part numbers containing the suffix ENG followed by a 4 digit number. Each of these products has been designed for a custom application for a particular customer. Custom products are guaranteed for one year, unless explicitly stated otherwise. During this period Zaber will repair any products with faults due to manufacturing defects, free of charge.

How to return products

Customers with devices in need of return or repair should contact Zaber to obtain an RMA form which must be filled out and sent back to us to receive an RMA number. The RMA form contains instructions for packing and returning the device. The specified RMA number must be included on the shipment to ensure timely processing.

Contact Information

Contact Zaber Technologies Inc by any of the following methods:

Phone	1-604-569-3780 (direct) 1-888-276-8033 (toll free in North America)
Fax	1-604-648-8033
Mail	#2 - 605 West Kent Ave. N., Vancouver, British Columbia, Canada, V6P 6T7
Web	www.zaber.com
Email	Please visit our website for up to date email contact information.

The original instructions for this product are available at <https://www.zaber.com/manuals/LHM>.

Appendix A: Default Settings

Please see [the Zaber Support Page](#) for default settings for this device.

Product Drawing

ZABER

LHM Motorized Linear Stage
dimensions in mm

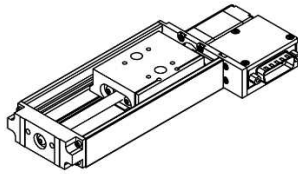

Model Number*	Travel	A	B
LHM025	25.4	148.2	89.2
LHM050	50.8	173.6	114.6
LHM100	101.6	224.4	165.4
LHM150	152.4	275.2	216.2
LHM200	203.2	326.0	267.0

*See product page for complete list of available models at www.zaber.com

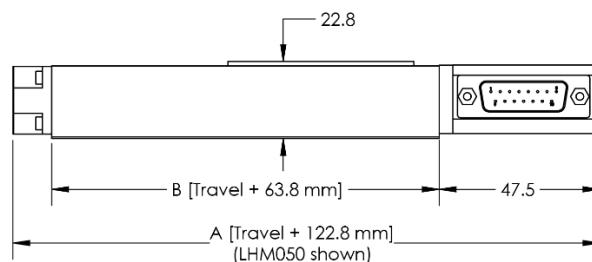
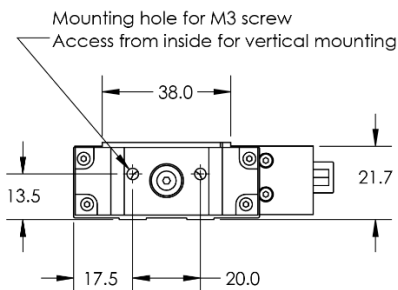
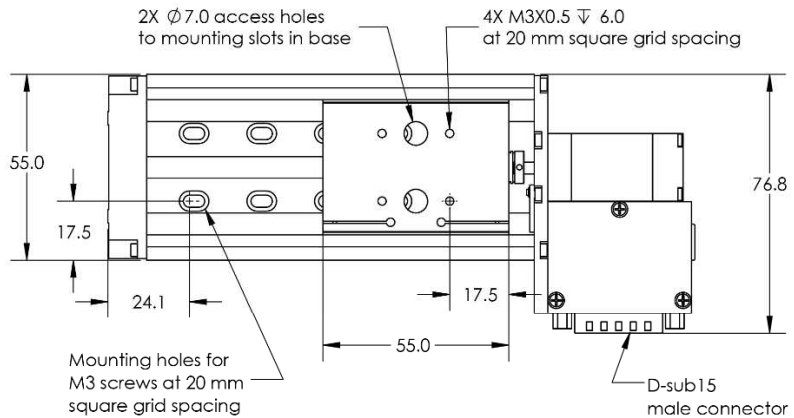

Specifications

Specification	Value	Alternate Unit
Microstep Size (Default Resolution)	0.124023437 μm	
Built-in Controller	No	
Recommended Controller	X-MCC (48 V) Recommended	
AutoDetect	Yes	
Repeatability	< 4 μm	< 0.000157"
Backlash	< 30 μm	< 0.001181"
Maximum Speed	65 mm/s	2.559"/s
Minimum Speed	0.000076 mm/s	0.000003"/s
Speed Resolution	0.000076 mm/s	0.000003"/s
Encoder Type	None	
Peak Thrust	25 N	5.6 lb
Maximum Continuous Thrust	25 N	5.6 lb
Maximum Centered Load	30 N	6.7 lb
Maximum Cantilever Load	50 N · cm	70.8 oz · in
Guide Type	Plain bearing	
Linear Motion Per Motor Rev	1.5875 mm	0.062"
Motor Steps Per Rev	200	
Motor Type	Stepper (2 phase)	
Motor Rated Current	600 mA/phase	
Motor Winding Resistance	6.5 ohms/phase	
Inductance	3.5 mH/phase	
Motor Connection	D-sub 15	
Default Resolution	1/64 of a step	
Mechanical Drive System	Lead screw	
Limit or Home Sensing	Magnetic hall sensor	
Axes of Motion	1	
LED Indicators	No	
Mounting Interface	M3 threaded holes	
Operating Temperature Range	0 to 50 ° C	
Vacuum Compatible	No	
RoHS Compliant	Yes	
CE Compliant	Yes	

Comparison

Part Number	Travel Range	Accuracy (unidirectional)	Weight
LHM025A-T3A	25.4 mm (1.000")	50 μm (0.001968")	0.30 kg (0.661 lb)
LHM050A-T3A	50.8 mm (2.000")	75 μm (0.002953")	0.36 kg (0.794 lb)
LHM100A-T3A	101.6 mm (4.000")	125 μm (0.004921")	0.42 kg (0.926 lb)
LHM150A-T3A	152.4 mm (6.000")	175 μm (0.006890")	0.46 kg (1.014 lb)
LHM200A-T3A	203.2 mm (8.000")	225 μm (0.008858")	0.52 kg (1.146 lb)

Charts and Notes

Thrust Speed Performance

